

Specifications

Output Power HP (kW)	7.5 (5.5)
Phase	3 Phase
Pole	4 Pole
Frame Number	132S

Degrees of Protection	IP 55
Enclosure Construction	Totally-enclosed Fan-cooled
Thermal Class	Class F (155 °C)

Alignment	Horizontal
Frame Material	Steel plate

Power Transmission	Direct-couple or Belt Driven
Direction of Rotation	Counterclockwise (CCW) viewed from shaft-end side

Connection Type	Terminal Block (6 Leads)
Coating Colour	Munsell N5.5 (Gray)
Conformed Standard	IEC 60034-1 & JEC-2137-2000

Voltage & Frequency	HT Type
	380~415V 50Hz
	380~440V 60Hz (suitable for Y-Δ starting)

* The perpendicular variation of tolerance for the shaft center is $\begin{matrix} 0 \\ -0.5 \end{matrix}$

Dimensions (mm)

Motor														
A	B	C*	D	E	F	G	H	I	J	K	L	M	ML	N
211.5	155	132	266	108	70	6.5	265	288	40	45	450.5	256	268	180

Motor			Terminal Box				Shaft End							
X	XB	Z	KA	KG	KD	KL	Q	QK	R	S	T	U	W	
4	89	12	75	96	PF 1	210	80	63	239	38 k6	8	5	10	

Bearing No.		Approximated Weight (kg)	Approximated Packing Dimensions (LxWxH)	Gross Weight (kg)
Drive End	Opposite			
6308ZZ	6207ZZ	48	579 x 435 x 347	56

Connection & Connection Diagram

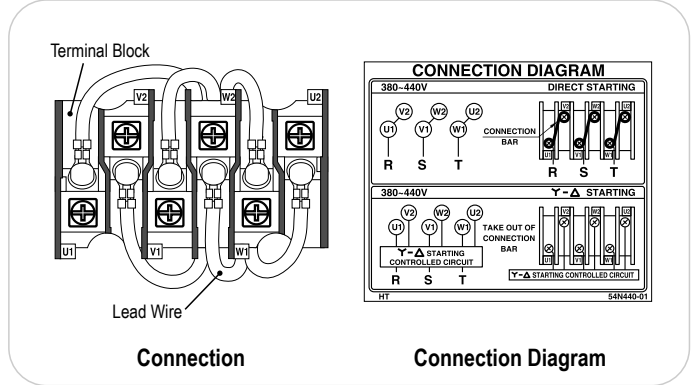

Circumstance Conditions

Ambient Temperature	-20 ~ +40°C
Ambient Humidity	95% RH or less
Operating Altitude	Less than 1,000m above sea level
Environment	No bursting / erosive gas or vapor

Motor Characteristics

Type	Hz	V	50% Load			75% Load			100% Load				Torque(%)		Is (A)	Inertia GD ² (kg-m ²)		
			(A)	Eff(%)	PF(%)	(A)	Eff(%)	PF(%)	(A)	Eff(%)	PF(%)	Speed (r/min)	Torque (kg-m)	Ts			Tm	
HT	50	380	6.49	0.83	0.77	8.94	0.85	0.82	11.6	0.86	0.84	1430	3.75	203	238	58.9	0.091	
		415	6.94	0.80	0.69	8.63	0.86	0.77	10.9	0.86	0.81	1440	3.72	245	288			64.8
	60	380	5.96	0.83	0.84	8.40	0.85	0.87	11.1	0.85	0.88	1720	3.11	172	190			49.6
		440	6.10	0.79	0.75	7.95	0.83	0.82	10.1	0.85	0.85	1740	3.08	236	266			58.4